



ZEC310 Zone Damper and BYP200 Bypass Damper Controllers

Installation Instructions
LC-ZEC310-0, LC-BYP200-0

Part No. 24-10143-1248, Rev. C
Issued June 2018

Refer to the [QuickLIT website](#) for the most up-to-date version of this document.

Applications

The Zone Damper (ZEC310) and Bypass Damper (BYP200) Controllers are components of the Verasys® zoning system. The Zone and Bypass Damper Controllers run a pre-engineered HVAC zoning application and provide the inputs and outputs required for this application. These controllers ship factory-configured for field installation on a Verasys system Zone or Bypass Damper assembly.

The Zone and Bypass Damper Controllers include advanced operating modes and multiple features that ensure occupant comfort. The Zone Damper uses a carbon dioxide (CO₂) demand controlled ventilation (DCV) mode to regulate CO₂ levels within a zone. This occurs when fresh air enters the zone during occupied times. Occupancy sensing capability enables the controller to switch from occupied mode to standby mode based upon the presence of local activity. Standby mode maximizes energy savings by using setpoints that are higher and lower than occupied mode setpoints.

See the [Zone Controller Accessories](#) table for additional information on optional features. For further information on these types of operations, refer to the *Verasys System User's Guide (LIT-12012371)*.

North American Emissions Compliance

United States

This equipment has been tested and found to comply with the limits for a Class A digital device pursuant to Part 15 of the FCC Rules. These limits are designed to provide reasonable protection against harmful interference when this equipment is operated in a commercial environment. This equipment generates, uses, and can radiate radio frequency energy and, if not installed and used in accordance with the instruction manual, may cause harmful interference to radio communications. Operation of this equipment in a residential area may cause harmful interference, in which case the users will be required to correct the interference at their own expense.

Canada

This Class (A) digital apparatus meets all the requirements of the Canadian Interference-Causing Equipment Regulations.

Cet appareil numérique de la Classe (A) respecte toutes les exigences du Règlement sur le matériel brouilleur du Canada.

Installation

Follow these guidelines when you install a Zone Damper and Bypass Damper Controller:

- Transport the controllers in the original container to minimize vibration and shock damage.
- Do not drop the controller or subject it to physical shock.

Parts Included

- One controller with removable Zone and Sensor Buses and power terminal blocks.
- One self-drilling No. 10 x 25 mm (1 in.) screw.

Materials and Special Tools Needed

- 6 mm (1/4 in.) female spade terminals for input and output wiring and crimping tool or spade mounted terminal blocks.
- A small straight-blade screwdriver for securing wires in the terminal blocks.
- An 8 mm (5/16 in.) wrench or 10 mm (3/8 in.) 12-point socket to tighten the square coupler bolt.
- Shims or washers to mount the controller, if necessary.
- A power screwdriver, 100 mm (4 in.) extension socket, or a punch, drill, and 3.5 mm (9/64 in.) drill bits to mount the ZEC.
- A pliers to open and close the damper.
- 3.97 mm (5/32 in.) ID poly tubing.

Mounting

Follow these guidelines when you mount a Zone Damper and Bypass Damper Controller:

- Ensure that the mounting surface can support the controllers and any user-supplied enclosure.
- Mount the controller on a hard, even surface whenever possible.
- Use shims or washers to mount the controller securely and evenly on the mounting surface.
- Mount the controller in an area free of corrosive vapors that matches the ambient conditions specified in the Technical Specifications section.
- Provide sufficient space around the controller for cable and wire connections and adequate ventilation through the controller. Provide at least 50 mm (2 in.) on the top, bottom, sides, and front of the controllers.
- Do not mount the controller in areas where electromagnetic emissions from other devices or wiring can interfere with controller communication.
- Avoid mounting the controller on surfaces with excessive vibration.

Follow these additional guidelines when you mount a field controller in a panel or enclosure:

- Do not install the controller in an airtight enclosure.
- Mount the controller so that the enclosure walls do not obstruct cover removal or ventilation through the controller.
- Mount the controller so that the power transformer and other devices do not radiate excessive heat to the controller.

Follow these guidelines to mount the controllers:

1. Ensure you wear the appropriate personal protective equipment (PPE), such as hard hat, safety glasses, steel toe boots, and gloves.
2. Disconnect power from the controller transformer as well as heater circuits, if applicable.
3. Set all the switches on the field controller to their known settings, and then set the MS/TP address, and ensure that end-of-line (EOL) is set to Off. Refer to the *Versasys Zone Coordinator Installation Instructions (Part No. 24-10143-1280)* for proper switch setting.
4. Place the controller in the proper mounting position on the actuator shaft so that the wiring connections are easily accessible. Make sure the controller base is perpendicular to the damper shaft. If needed, use a spacer to offset tipping of the controller caused by the shaft bushings.

Note: Use the alignment marks to center the captive spacer to ensure sufficient ZEC/BYP controller movement in either direction (Figure 5).

5. Secure the self-drilling No. 10 screw through the captive spacer with a power screwdriver and 100 mm (4 in.) extension socket. Alternatively, use a punch to mark the position of the shoulder washer, and then drill a hole using a 8 mm (5/16 in.) drill bit. Insert the mounting screw and tighten against the spacer.
6. Locate the damper position using the typical marking on the end of the damper shaft.
7. Note the direction, clockwise (CW) or counterclockwise (CCW), required to close the damper. The actuator setup depends on the necessary amount of rotation required for the damper to go from full-open to full-closed. For 90° rotation, install the damper full-closed. For 45° or 60° rotation, install the damper full-open.
8. Push down and hold the Manual Override button and turn the controller coupler until it contacts the mechanical end-stop at either the full-closed or full-open position.
9. If the damper for a 45° or 60° box closes CCW, rotate the coupler to the CW mechanical limit. If the damper for a 45° or 60° box closes CW, rotate the coupler to the CCW mechanical limit. This action sets the open end-stop; the closed end-stop is set by the closed damper.

For 45° and 60° boxes, hard stops must be provided at both full-closed and full-open damper positions. If you install the controller at the full-open position, the controller provides the open stop for 45° and 60° boxes. The closed damper seal provides the full-closed stop.
10. Tighten the square coupler bolt to the shaft using an 8 mm (5/16 in.) wrench or 10 mm (3/8 in.) 12-point socket. Tighten to 10.5 to 11.5 N·m (95 to 105 lb·in).
11. Put a loop in the poly tubing to trap condensation when you attach the poly tubing to the ZEC pressure transducer ports. Loop the poly tubing before you make the final connections.
12. Push the Manual Override button, and turn the actuator coupling manually to ensure that the actuator can rotate from full-closed to full-open positions without binding.
13. Complete the mounting by rotating the damper to the full-open position.

Wiring

CAUTION

Risk of Electric Shock.

Disconnect the power supply before making electrical connections to avoid electric shock.

ATTENTION

Risque de décharge électrique.

Débrancher l'alimentation avant de réaliser tout raccordement électrique afin d'éviter tout risque de décharge électrique.

IMPORTANT: Make all wiring connections in accordance with the National Electrical Code and local regulations. Use proper electrostatic discharge (ESD) precautions during installation and servicing to avoid damaging the electronic circuits of the controller.

IMPORTANT: Do not exceed the controller electrical ratings. Exceeding controller electrical ratings can result in permanent damage to the controller and void any warranty.

IMPORTANT: Do not connect supply power to the controller before finishing wiring and checking all wiring connections. Short circuits or improperly connected wires can result in damage to the controller and void any warranty.

IMPORTANT: Use copper conductors only. Make all wiring in accordance with local, national, and regional regulations.

IMPORTANT: Maintain proper polarity and voltage or current ratings. Improper polarity or exceeding the voltage or current ratings voids the warranty.

Input and Output Terminals

See Figure 5 for an ZEC310 wiring example.

Sensor Bus Terminal Block

The Sensor Bus terminal block is a brown, removable 4-terminal plug that is keyed to only fit into the board-mounted brown Sensor Bus. Wire the removable Sensor Bus terminal block plugs on the ZEC and other field devices in a daisy-chain configuration using 4-wire twisted, shielded cable as shown in the following figure.

Figure 1: Sensor Bus Terminal Block Wiring

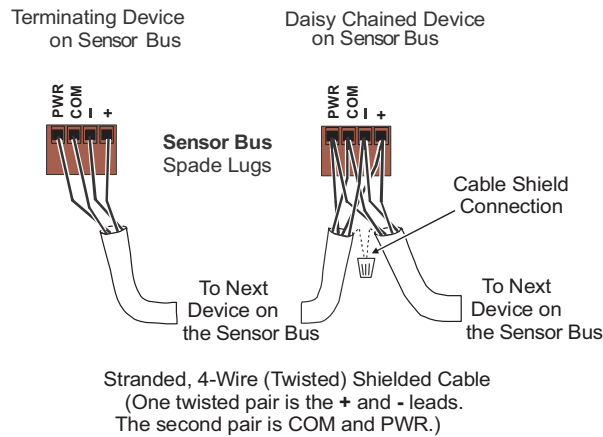

Zone Bus Terminal Block

Note: The Verasys System Zone Bus is equivalent to the ZEC310/BYP200 controller Zone Bus.

The Zone Bus terminal block is a gray, removable, 4-terminal plug with +15 VDC that fits into a board-mounted jack. Wire the removable Zone Bus terminal block plugs on the ZEC/BYP and other Zone Bus controllers in a daisy-chain configuration using 3-wire twisted, shielded cable as shown in Figure 2.

Figure 2: Zone Bus Terminal Block Wiring

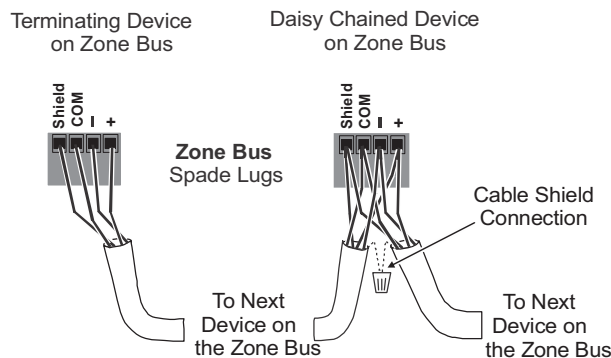

Modular Ports

The modular Sensor Bus and Zone Bus ports on the face of the controller are RJ-12 (6-position) modular jacks. The modular System Bus port provides a connection for the VAV Balancing Tool. The modular Sensor Bus port provides a connection for the VAV Balancing Tool. The Zone Bus port is not used in ZEC/BYP controller installations.

Figure 3: Pin Number Assignments for Sensor and Zone Bus on ZEC/BYP Controllers

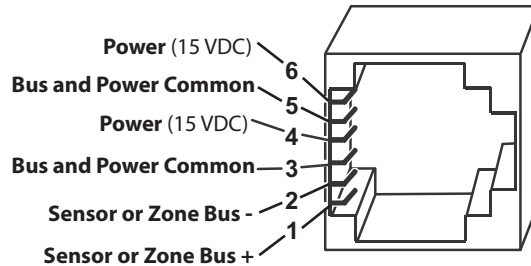

Supply Power Terminal Block

The 24 VAC supply power terminal block is a gray, removable, 2-terminal plug that fits into a board-mounted jack on the upper left of the ZEC/BYP controller. Wire the 24 VAC supply power wires from the transformer to the HOT and COM terminals on the terminal plug. The supply power wire colors may be different on transformers from other manufacturers. Refer to the transformer manufacturer's instructions and the project installation drawings for wiring details.

Figure 4: 24 VAC Supply Power Terminal Block Wiring

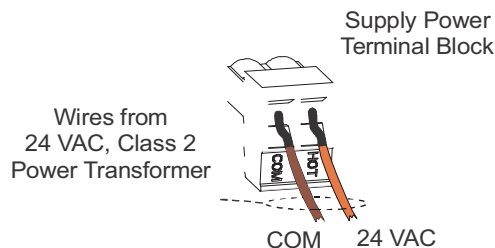

IMPORTANT: The 24 VAC power should not be shared with other network devices. Sharing power with other network devices may cause noise, interference, and ground loop problems. You may damage the controller by sharing power with other devices.

Follow these guidelines to wire the controller:

1. Terminate the ZEC wiring according to Figure 5. Terminate the BYP wiring according to Figure 6.
2. Wire the CO₂ sensor to the ZEC's Sensor Bus.
3. Wire the Zone Bus in a daisy chain.
4. Ensure that the controller's device address DIP switches are set to the appropriate device address. (See [Setup and Adjustments](#)). Also, activate the end-of-line (EOL) switch if necessary.

IMPORTANT: Maintain proper polarity and voltage or current ratings. Improper polarity or exceeding the voltage or current ratings voids the warranty.

5. Connect the controller to 24 VAC, Class 2 power.

Figure 5: ZEC310 Controller - Wiring Example

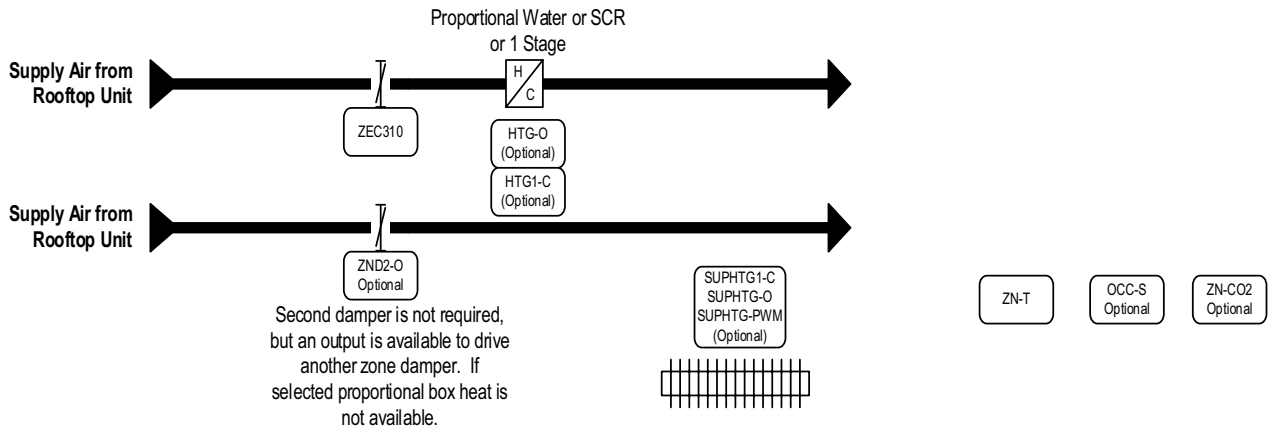

Figure 1: BYP200 Flow Diagram

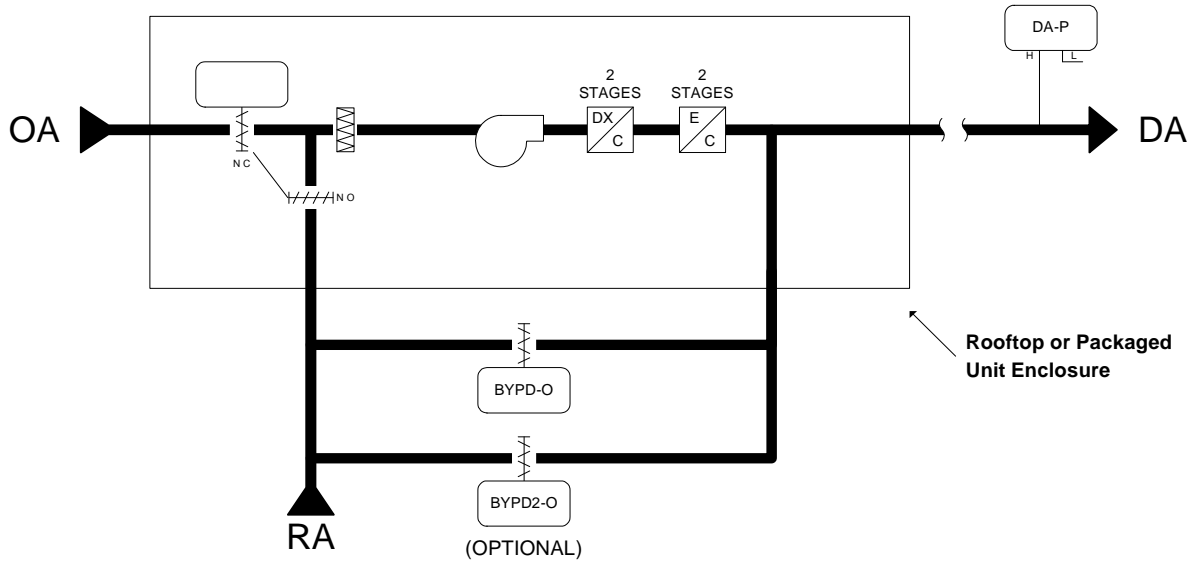

Figure 1: ZEC310 Controller Wiring Example

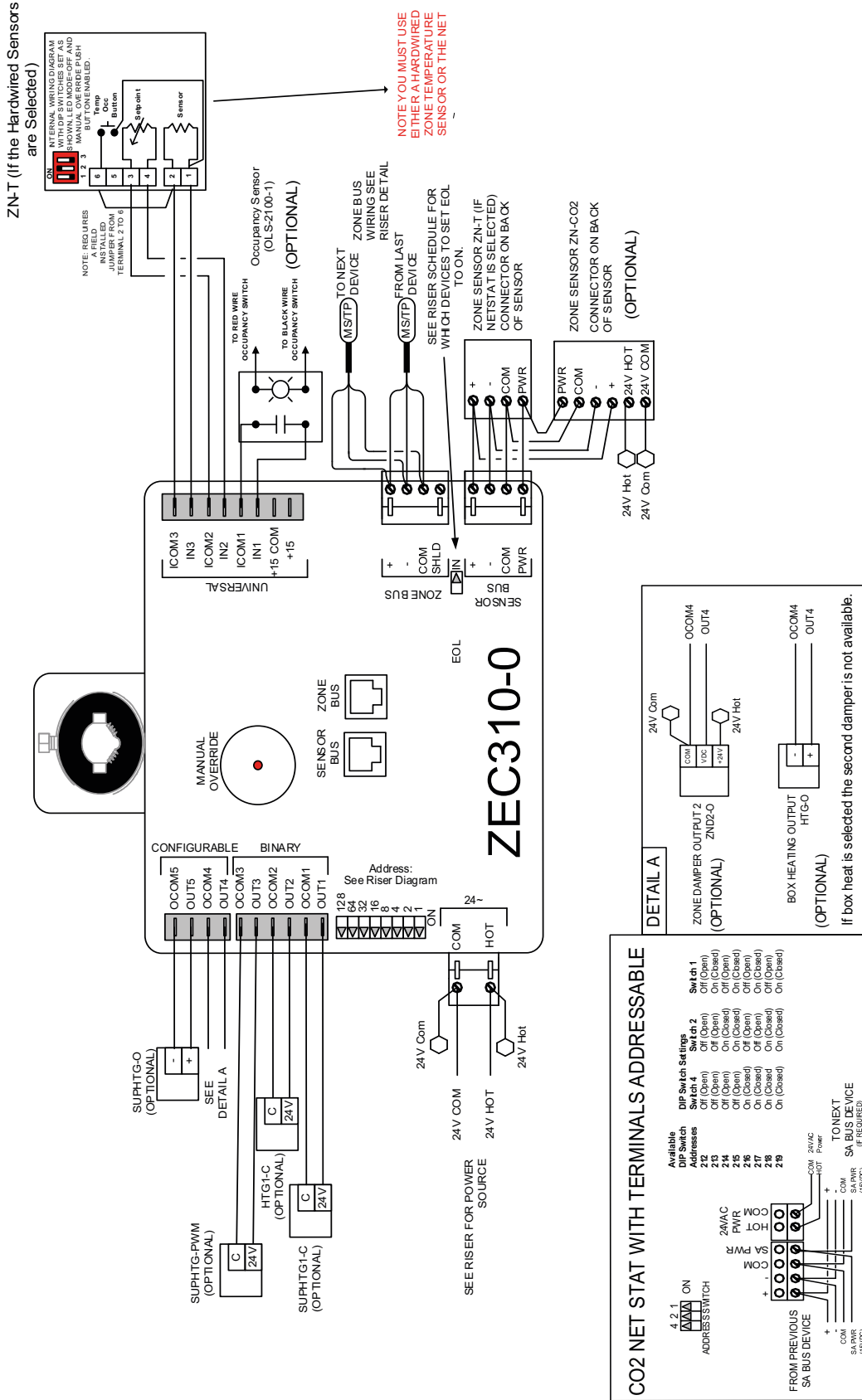
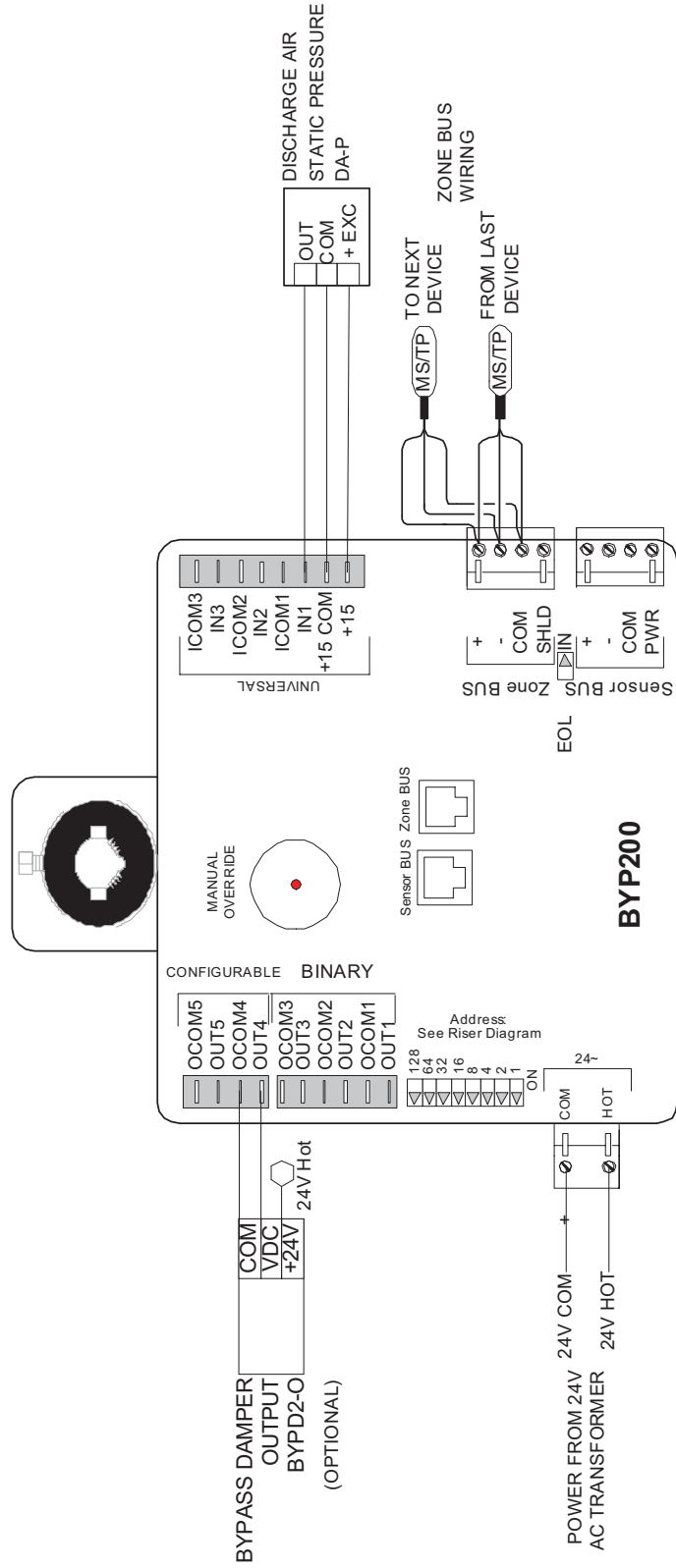

Figure 8: BYP200 Wiring Diagram



BYP200 Sequence of Operation

In occupied mode, the Bypass Damper Controller monitors the duct static pressure. When the static pressure raises above the setpoint, the Bypass Damper opens to decrease the pressure. When the static pressure drops below the setpoint, the Bypass Damper modulates closes to increase pressure.

In unoccupied mode, when the single packaged unit is OFF, the Bypass Damper modulates to 50%. If the single packaged unit is ON, the Bypass Damper controls to the occupied mode sequence.

ZEC Terminal Functions, Ratings, Requirements, and Wiring Guidelines

Input and Output Wiring Guidelines

Table 1 provides information about the functions, ratings, and requirements for the ZEC input and output terminals.

In addition to the wiring guidelines in Table 1, follow these guidelines when wiring ZEC inputs and outputs:

- Run all low-voltage wiring and cables separate from high-voltage wiring.
- It is best practice to ensure all input and output cables, regardless of wire size or number of wires, consist of twisted, insulated, and stranded copper wires.
- Shielded cable is not required for input or output cables.
- It is best practice to use shielded cable for input and output cables that are exposed to high electromagnetic or radio frequency noise.

Sensor and Zone Bus Supply Power Wiring Guidelines

Table 1 provides information about terminal block functions, ratings, and requirements.

In addition to the guidelines in Table 1, follow these guidelines when wiring the Sensor and Zone Buses and supply power:

- Run all low-voltage wiring and cables separate from high-voltage wiring.
- It is best practice to ensure all Zone and Sensor Bus cables, regardless of wire size, consist of twisted, insulated, stranded copper wire.
- Shielded cable is strongly advised for all Zone and Sensor Bus cables.
- Refer to the Verasys® BACnet® MS/TP Communications Bus Technical Bulletin (LIT-12012362) for detailed information regarding wire size and cable length requirements for the Sensor and Zone Buses.

Wire Gauges and Lengths

Table 1: Zone Controller Wiring

Terminal	Terminal Labels	Function and Electrical Ratings/ Requirements	Recommended Cable Type and Length
Analog Input (AI)	IN1	Provides a BI connection for occupancy sensor (OCC-S) dry contact (optional)	0.6 mm (22 AWG) stranded, 2-wire twisted cable recommended for runs of <30 m (90 ft).
	IN2	Provides an AI connection for Warmer/Cooler adjust (optional)	
	IN3	Provides an AI connection for zone temperature (ZN-T) sensor. (optional) Note: You can wire either a network sensor or a zone sensor to AI13.	
Binary Output (BO)	(Integrated)	Provides a BO connection for clockwise (CW) rotation to (Open) of actuator, 24 VAC triac output.	N/A
	(Integrated)	Provides a BO connection for counterclockwise (CCW) rotation to (Close) of actuator, 24 VAC triac output.	N/A
Sensor Bus Terminal Block	+, -, COM, PWR	Sources 15 VDC power for Sensor Bus devices; supports 1 NS Series Network CO ₂ Sensor and 1 NS Series Network Sensor.	0.6 mm (22 AWG) stranded, 4-wire twisted cable recommended for runs of <30 m (99 ft)
Zone Bus Terminal Block	+ - COM	Provides communication network	0.6 mm (22 AWG) stranded, twisted shielded cable recommended for runs of 1,000 feet maximum
24 VAC Power	HOT	AC supply input supply 20–30 VAC (Nominal 24 VAC)	0.8 mm to 1.5 mm (20 to 16 AWG) 2-wire
	COM	24 VAC power common	
Configurable Output (CO)	OUT4	Select box heat for an output signal of 0-10V to control box heat. Set the box heat to false for a 0-10V output signal to drive a second damper actuator. Note: Box heat is a heating output that is in the duct.	0.6 mm (22 AWG) stranded, 3-wire twisted cable recommended for runs of <30 m (99 ft)
	OUT5	Provides a 0-10V Supplemental Heating Output. Supplemental heat is heat that is outside the duct.	
Binary Output (BO)	OUT1	Provides a 24VAC to turn on a supplemental heat command.	0.8 mm to 1.5 mm (20 to 16AWG) 2-wire.
	OUT2	Provides a 24VAC to turn on a box heat command.	0.8 mm to 1.5 mm (20 to 16AWG) 2-wire.
	OUT3	Provides a PWM 24VAC signal with a 10 second cycle for a supplemental heat PWM command.	0.8 mm to 1.5 mm (20 to 16AWG) 2-wire.

Table 2: Bypass Controller Wiring

Terminal	Terminal Labels	Function and Electrical Ratings/ Requirements	Recommended Cable Type and Length
Analog Input (AI)	AI-1	Provides an AI connection for duct static pressure sensor, 0.0 to 5.0 VDC, 0 to 5 W.C.	0.6 mm (22 AWG) stranded, 2-wire twisted cable recommended for runs of <30 m (90 ft).
Binary Output (BO)	(Integrated)	Provides a BO connection for clockwise (CW) rotation to (Open) of actuator, 24 VAC triac output.	N/A
	(Integrated)	Provides a BO connection for counterclockwise (CCW) rotation to (Close) of actuator, 24 VAC triac output.	N/A
Zone Bus Terminal Block	+ - COM	Provides communication network	0.6 mm (22 AWG) stranded, twisted shielded cable recommended for runs of 1,000 feet maximum
24 VAC Power	HOT	AC supply input supply 20–30 VAC (Nominal 24 VAC)	0.8 mm to 1.5 mm (20 to 16 AWG) 2-wire
	COM	24 VAC power common	
Configurable Output (CO)	OUT4	Provides an analog output signal of 0 to 10 V to drive a second Bypass Damper actuator.	0.6 mm (22 AWG) stranded, 3-wire twisted cable recommended for runs of <30 m (90 ft).

Setup and Adjustments

Setting the Device Address

ZEC controllers are master devices on BACnet® MS/TP Sensor or Zone Buses. Before operating field controllers on a bus, you must set a valid and unique device address for each controller on the bus.

To set a field controller’s device address, place the positions of the switches on the device address DIP switch block, at the top of the controller. Device addresses 6 through 37 are the valid addresses for the ZEC/BYP Controller.

Note: The ZEC/BYP Controllers ship with all address switches set to ON. Set a valid and unique device address on the field controller before applying power to the controller on the bus.

The DIP switch block has eight switches numbered 128, 64, 32, 16, 8, 4, 2, and 1.

To set the device addresses on a field controller follow these steps:

1. Set all of the switches on the field controller’s device address DIP switch block (128 through 1) to OFF.
2. Set one or more of the six address switches (32 through 1) to ON, so that the sum of the switch numbers set to ON equals the intended device address.
3. Set the highest number switch that is less than or equal to the intended device address to ON. Then continue setting lower numbered switches until the total equals the intended address. For example, if the intended device address is 21, set Switch 16 to ON first, then set Switch 4 ON, followed by Switch 1 (16+4+1=21).
4. Set a unique and sequential device address for each of the field controllers connected on the System Bus or Zone Bus, starting with device address 6.

To ensure the best bus performance, set sequential device addresses with no gaps in the device address range (6, 7, 8, 9, and so on). The field controllers do not need to be physically connected on the bus in their numerical device address order.

5. Write each field controller’s device address on the white label below the DIP switch block on the controller’s cover.

Refer to the *Verasys® BACnet® MS/TP Communications Bus Technical Bulletin (LIT-12012362)* for more information on field controller device addresses and how to set them on MS/TP Bus devices.

Duct Static Pressure Probe Requirement

The Bypass Damper requires the use of a duct static pressure probe (FTG618A-600R) and 6.4 mm (1/4 in.) I.D. user-supplied tubing. The tubing must connect to the probe and link the H1 (+) port of the pressure sensor, located on the Bypass Damper controller.

Accessories

Table 3 lists the Zone controller accessories. Table 4 lists the Bypass Controller accessories.

Table 3: Zone Controller Accessories

Product Code Number	Description
Zone Temperature Sensors (Hardwired)	
TE-68NT-0N00S	Wall temperature sensor, 1k ohm, nickel with temperature occupancy button.
TE-68NT-1N00S	Wall temperature sensor, 1k ohm, nickel with warmer/cooler (W/C) adjustment and temperature occupancy pushbutton.
Zone CO₂ Sensor	
NS-BCN7004-0	BACnet network CO ₂ sensor designed to function directly with Johnson Controls® BACnet MS/TP digital controllers, in a 80 mm x 120 mm (3 in. x 4.5 in.) enclosure with terminal block and modular jack wiring connections. Note: Only addresses 212 to 214 are supported.
Second Zone Damper Actuator¹	
M9106-GGA-2	6 N-m torque non-spring return damper actuator
Network Sensors for Zone Temperature	
NS-BTB7003-0	Network sensor, 120 x 80, Johnson Controls logo, local setpoint, terminals
NS-BTB7003-2	Network sensor, 120 x 80, no logo, local setpoint, terminals
NS-BTN7003-0	Network sensor, 120 x 80, no logo, no setpoint, terminals
NS-BTN7003-2	Network sensor, 120 x 80, no logo, no setpoint, terminals
NS-BTP7002-0	Network sensor, 120 x 80, Johnson Controls logo, warmer/cooler adjustment, terminals
NS-BTP7002-2	Network sensor, 120 x 80, no logo, W/C adjustment, terminals
Occupancy Lighting Switch	
NS-BCN7004	Occupancy sensing light switch for control of indoor incandescent and fluorescent lights
RIBU1C	Enclosed relay for OLS-2100-1 Sensor

1. You must purchase the actuator and add it to a damper without a ZEC310 controller.

Table 4: Bypass Controller Accessories

Product Code Number	Description
DPT2640-005D	264 Series Low Differential Pressure Transducer to measure differential air pressure. The transducer senses static pressure and converts this pressure difference to a proportional analog output. Accuracy +/- 5% with a 0 to 5 VDC range. Units available in voltage or currents.
FTG18A-600R ¹	Duct static pressure probe kit: 4 in. flanged sensing tube, two barbed fittings, two No. 10 screws, and O-gasket.
M9106-GGA-2	6 nm torque non-spring return damper actuator

1. The duct static pressure probe is field-installed and required for use with the Bypass Controller. See the *Duct Static Pressure Probe Requirement* section.

Operation

The ZEC/BYP controller is pre-programmed for the operating sequence as ordered. You do not need to program the controller; however, you need to provide configuration information using either the Balancing Sensor or the Zone Setup screen on the Verasys Smart Building Hub (SBH).

For detailed information on Verasys system operation, including dehumidification capability, DCV, occupancy sensing, and general operating modes, refer to the *Verasys System Operation Overview Technical Bulletin (LIT-12012370)*.

Occupancy Sensor

All zone controllers support an occupancy sensor. The occupancy sensor enables the controller to switch from occupied mode to standby mode. This occurs in normal occupied mode during a set time period, when local activity is absent. When in standby mode, the zone controller uses standby temperature setpoints that are higher and lower than the occupied cooling and occupied heating temperature setpoints. These standby setpoints save energy by reducing the demand for heating and cooling in an unoccupied zone. For Zone Dampers, the sensor uses unoccupied flow setpoints in addition to standby temperature setpoints. You can enable the occupancy sensor in the Zone Setup screen of the System Manager or Zone Coordinator. You can set occupancy sensitivity and time delay until standby locally at the sensor. Refer to the *Verasys System User's Guide (LIT-12012370)* for more information.

CO₂ Demand Controlled Ventilation (DCV)

CO₂ DCV monitors CO₂ levels using a wall-mounted CO₂ sensor. This ensures high indoor air quality (IAQ) for the zone. The sensor measures CO₂ levels on a scale of 0 to 2,000 parts per million (ppm). When the CO₂ sensor detects that CO₂ levels in the zone are above the setpoint, such as when a high number of occupants are within the zone, the Zone Damper opens to allow more outside air into the zone. You can enable CO₂ DCV in the Zone Setup screen of the System Manager or Zone Coordinator. Refer to the *Verasys System User's Guide (LIT-12012370)* for more information.

Troubleshooting

Use the following information to troubleshoot the ZEC/BYP controllers.

Power Status LED

A green LED shows the power supply status for the Zone Damper Controller. See Table 5 for a description of modes.

Table 5: Status LED for Power (PWR)

Mode	Description
Off	No Power
On	Power is supplied by Primary Voltage (Normal operation)

Communication Bus Problems

Several factors may influence the functioning of the Zone Communication Bus.

I/O Wiring

It is important that the ZEC/BYP controller is wired properly. If the ZEC/BYP controller is wired incorrectly, communication problems can occur. These problems include devices going online and offline or devices not coming online at all.

Incomplete Address

The ZEC/BYP controller must have the address switch set to a range between 6–37. Other settings prevent the controllers from communicating on the network.

Duplicate Addresses

Two or more devices on a Communication bus cannot have the same address. For example, two controllers on the Zone Communication Bus cannot both have an address of 18. If two devices on the same bus have the same address, performance can degrade or serious communication problems can occur. These problems include the devices not coming online and all communication stopping completely.

Depending on the severity of the situation, check for duplicate addresses in the following ways:

- If the bus performance is degraded, check the address switch settings at the devices with unreliable communications.
- If a specific device is not communicating, remove the device with communication problems and check if the device address remains online at the SBH.
- If the bus communication problems are severe and no communication is present, or you cannot determine where communication is unreliable, disconnect and isolate a portion of the bus for testing purposes, and test the bus portion connected to the Zone Coordinator.

Correcting Physical Communication Bus Problems

The Communication Bus is subject to a number of physical factors that can affect performance. Consider the following list of common physical problems that affect the Communications Bus:

- Check status LED to verify power at the controller
- Check wires
 - Verify that the wire is a 0.6 mm (22 AWG) three-conductor, twisted, shielded cable.
 - Verify that the shield is continuous and hard-grounded at one end.
- Check wiring
 - Check for and eliminate T-Taps, wire configurations that create a T shape and star configurations.
 - Ensure that the bus is wired in a daisy-chain fashion.
 - Verify that appropriate devices have three wires entering and exiting each terminal. Devices at the ends of the trunk do not have this wiring.
- Check EOL switch settings
 - Verify that only the EOL switch at the end of the system bus is set to ON, and all other system bus EOL switches are set to OFF.
- Check connections, polarity, and lengths
 - Verify that communications loops are less than approximately 304 m (1,000 ft) total in length.
 - If you are using one transformer to power multiple devices, verify that the device 24 VAC power connection follows the polarity of the common and 24 V terminations.
- Check for opens and shorts
- Check terminations
- Check addresses
 - Check for duplicate addresses.
 - Verify that the address range is sequential.
- Check for sources of interference
- Check bus voltages:
 - (+) to COM must be within 2.0 to 3.0 VDC

- (-) to COM must be within 1.5 to 2.54 VDC
- (+) to (-) must be within 0.3 to 1.0 VDC

Note: Values may fluctuate due to ongoing communications; this operation is normal provided that the voltage is within the defined range.

Repair Information

If the ZEC310 or BYP200 Controller fails to operate within its specifications, replace the unit. For a replacement unit, contact your nearest Verasys representative.

Technical Specifications

ZEC310 Zone and BYP200 Bypass Controllers

Product Code Number	LC-ZEC310-0: Field Installed, Zone Damper Controller LC-BYP200-0: Field Installed Bypass Damper Controller
Power Supply Requirement	24 VAC (nominal, 20 VAC minimum/30 VAC maximum), 50 to 60 Hz, Class 2 power supply (North America) or Safety Extra-Low Voltage (SELV) (Europe)
Power Consumption	10 VA (not including external load) Note: VA ratings do not include any power supplied to the peripheral devices connected to Binary Outputs (BOs) or Configurable Outputs (COs), which can each consume up to 12 VA per BO or CO, for a possible total consumption of an additional 60 VA (maximum).
Ambient Conditions	Ambient Operating Conditions: 0°C to 50°C (32°F to 122°F) Ambient Storage Conditions: -40°C to 70°C (-40°F to 158°F)
Processor	RX630 32-bit Renesas® microcontroller
Memory	1 MB flash memory and 512 KB Random Access Memory (RAM)
Input and Output Capabilities	1 - Universal Input: Defined as 0–10 VDC, 4–20 mA, 0–600k ohm, or Binary Dry Contact 3 - Binary Outputs: Defined as 24 VAC Triac (internal power source) 2 - Configurable Outputs: Defined as 0–10 VDC or 24 VAC Triac BO
Analog Input/Analog Output Accuracy	Analog Input: 15-bit resolution on UIs Analog Output: 0-10 VDC ± 200 mV
Mounting	Mounts to damper shaft using single set screw and to duct with single mounting screw
Actuator Rating	4 N•m (35 lb•in) minimum shaft length = 44 mm (1-3/4 in.)
Dimensions (Height x Width x Depth)	165 mm x 125 mm x 73 mm (6.5 in. x 4.92 in. x 2.9 in.)
Differential Pressure Transducer (BYP200 only)	Range: 38.1 mm to 38.1 mm (1.5 in. to 1.5 in.) W.C. Performance Characteristics: Accuracy ±1.3% Full Span Maximum (± .039 in. W.C.) Typical accuracy at zero (null) pressure is ±.02% full scale
Shipping Weight	0.65 kg (1.45 lb)
Compliance	United States: UL Listed, File E107041, CCN PAZX, UL 916, Energy Management Equipment FCC Compliant to CFR47, Part 15, Subpart B, Class A. Canada UL Listed, File E107041, CCN PAZX7, CAN/CSA C22.2 No. 205, Signal Equipment Industry Canada Compliant, ICES-003 Australia and New Zealand: RCM, Australia/NZ Emissions Compliant. Europe: CE Mark - Johnson Controls declares that this product is in compliance with the essential requirements and other relevant provisions of the EMC Directive.



The performance specifications are nominal and conform to acceptable industry standards. For application at conditions beyond these specifications, consult the local Johnson Controls office. Johnson Controls shall not be liable for damages resulting from misapplication or misuse of its products.

European Single Point of Contact:

JOHNSON CONTROLS
WESTENDHOF 3
45143 ESSEN
GERMANY

NA/SA Single Point of Contact:

JOHNSON CONTROLS
507 E MICHIGAN ST
MILWAUKEE WI 53202
USA

APAC Single Point of Contact:

JOHNSON CONTROLS
C/O CONTROLS PRODUCT MANAGEMENT
NO. 22 BLOCK D NEW DISTRICT
WUXI JIANGSU PROVINCE 214142
CHINA



www.johnsoncontrols.com

*Verasys® and Johnson Controls® are registered trademarks of Johnson Controls.
All other marks herein are the marks of their respective owners. © 2018 Johnson Controls.*